

Smart battery sensor with CAN interface

The MM9Z1_638 by NXP is an integrated battery monitoring system. It features CAN and LIN 2.2 connectivity.

(Source: Fotolia)

The integrated circuit (IC) supports current measurement via an external shunt resistor. The chip features four voltage measurements via internal calibrated resistor dividers or external dividers. It includes an internal temperature sensor, allowing close proximity battery temperature measurements, plus four external temperature sensor inputs.

One implemented 16-bit Sigma-Delta analog/digital converter senses the current. The converter input is connected to the output of a programmable gain amplifier (PGA) with four different gains. The PGA gain selection can be either user selectable or automatically selected. The user can choose, which gains are used by the automatic selection. The converted value available in the output register has a fixed value, independent of the selected gain. The output value is a signed value available on a 24-bit range register. The external shunt value can be selected from one of the following values: 50 $\mu\Omega$, 75 $\mu\Omega$, 100 $\mu\Omega$, 150 $\mu\Omega$, and 200 $\mu\Omega$.

The sensor IC features a battery voltage measurement with one 16-bit second-order Sigma-Delta analog/digital converter. The converter input is connected to the output of a multiplexer allowing selection of voltage sense with an internal resistor divider or a direct voltage sense. The voltage and current converters are synchronized.

There is also a third 16-bit Sigma-Delta analog/digital converter for temperature measurements. Its input

is linked to the output of a multiplexer, which allows selecting the internal temperature sensor or the external sensors via the direct voltage sense.

Each of the three A/D converters has its own set of registers for offset and gain compensations. The user can access and use these to enhance system performance, taking into account external components.

These peripherals are connected to the integrated S12Z central processing unit (CPU) by means of a die-to-die initiator (D2DI), which represents the communication interface to the companion (analog) die. It offers 128 KiB of flash memory and 8 KiB of SRAM. Additionally, there are up to eight general-purpose inputs and outputs

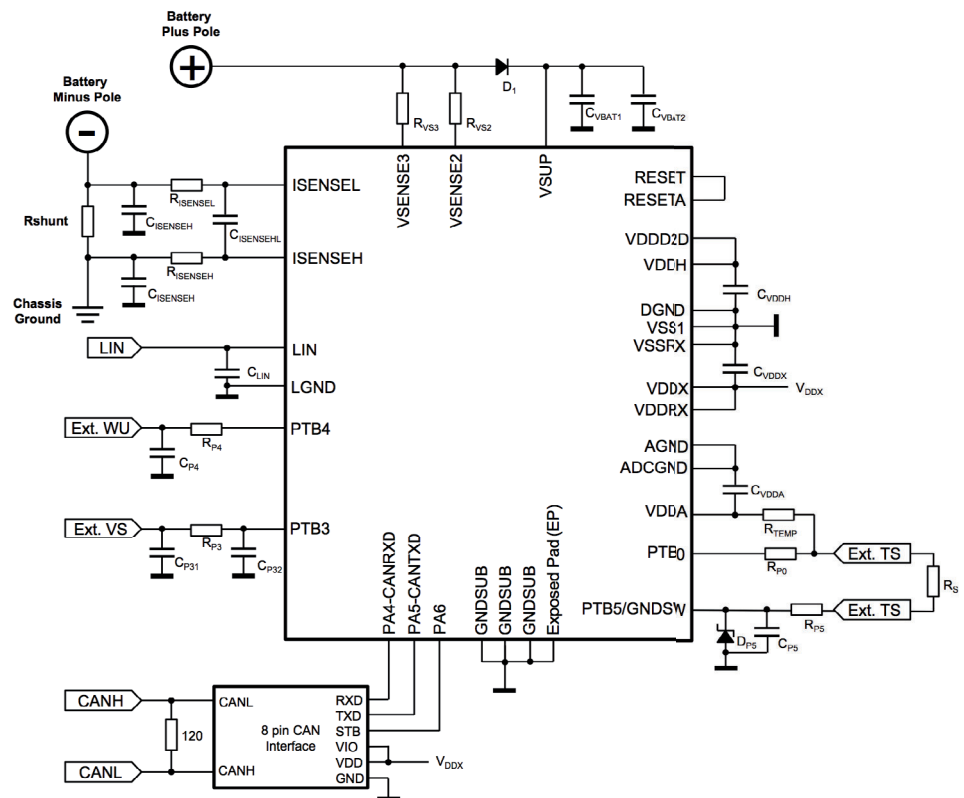

Figure 1: Typical application of the smart sensor controller with an on-chip CAN module, to connect it to the CAN network just a CAN transceiver needs to be added (Source: NXP)

(GPIO) as well as one Serial Peripheral Interface (SPI) port. The CPU also features an interrupt module and debug-capabilities via the on-chip debug module (DBG) in combination with the Background Debug Mode (BDM) interface.

The chip is optimized to monitor automotive 12-V starter batteries, but can also be used in other battery monitoring applications, like UPS (uninterruptible power supplies) or emergency/backup supplies (as are used in elevators, and so on).

Some CAN interface details

Besides the [LIN](#) interface, the IC features an on-chip CAN module. This CAN controller is based on the MSCAN implementation. It overcomes priority inversion problems and complies with the ISO 11898-1:2003 standard. This means it supports the Classical CAN protocol with 11-bit and 29-bit CAN-ID data frame formats. Bit-rates up to 1 Mbit/s can be configured. The CAN module features five receive buffers with a FIFO storage scheme and three transmit buffers with internal prioritization to avoid priority inversions. The CAN implementation allows aborting of not yet transmitted data and remote frames.

The module provides maskable ID filter supporting two 32-bit masks, four 16-bit masks, or eight 8-bit masks, programmable wake-up functionality (with integrated low-pass filters). The loop-back mode enables self-test operation and the listen-only mode can be used for monitoring the CAN network. Other features include programmable bus-off recovery functionality and separate signaling and interrupt capabilities for all CAN receiver and transmitter error states (warning, error passive, bus-off). The Transmit Error Counter (TEC) and the Receive Error Counter (REC) are readable. There are internal timers for time-stamping of received and transmitted frames. The CAN module has three low-power modes: sleep, power-down, and MSCAN enabled.

Diagnostic features

The MM9Z1_638 provides self-diagnostics. This includes the CPU functions, the analog die, and some application-specific features. Diagnostics during runtime is achievable by connecting a known signal to the input of the acquisition channel, performing an acquisition and comparing the result against the expected value. This has to be performed for each of the three acquisition channels, individually. The expected value varies from device to device, therefore a device-specific diagnostic value is measured during final test of the device, and is stored in non-volatile flash memory of each device.

Literature

- [1] MM9Z1_638D1: Intelligent battery sensor with CAN and LIN (2016-11, Revision 5.0)
- [2] AN5299: MM9Z1_638 diagnostic features (2016-07-14)

hz

www.can-cja.org

Industrial Ethernet Gateways/Bridges

**CAN/CANopen
EtherCAT
PROFINET
CAN-to-Cloud**



CANopen

**PROFI
NET**

EtherCAT

CAN-EtherCAT

- Gateway between CAN/CANopen and EtherCAT
- Additional Ethernet interface for EoE

ECX-EC

- EtherCAT slave bridge
- Process data exchange between two independent EtherCAT networks
- DC synchronization between EtherCAT masters

CANopen-PN

- Gateway between PROFINET-IO and CANopen
- PROFINET-IRT capable
- Simple configuration via S7 manager or TIA portal

CAN-to-Cloud

- Easy connection of CAN networks to the Microsoft Azure Cloud
- Control of CAN networks
- Control the CAN network from anywhere in the world

Besuchen Sie uns auf der
sps ipc drives



**Nürnberg 27.-29.11.2018
Halle 5, Stand 131**



esd electronics gmbh
Vahrenwalder Str. 207
30165 Hannover
Germany
Tel.: +49-511-3 72 98-0
info@esd.eu
www.esd.eu

US office:
esd electronics, Inc.
70 Federal Street - Suite #2
Greenfield, MA 01301
Phone: 413-772-3170
us-sales@esd-electronics.com
www.esd-electronics.us