

Automotive CAN protection

In the harsh automotive environment, careful design and proper TVS (transient voltage suppression) diodes are crucial for safeguarding the communication networks and interfaces. Semtech's portfolio of TVS products protects CAN.

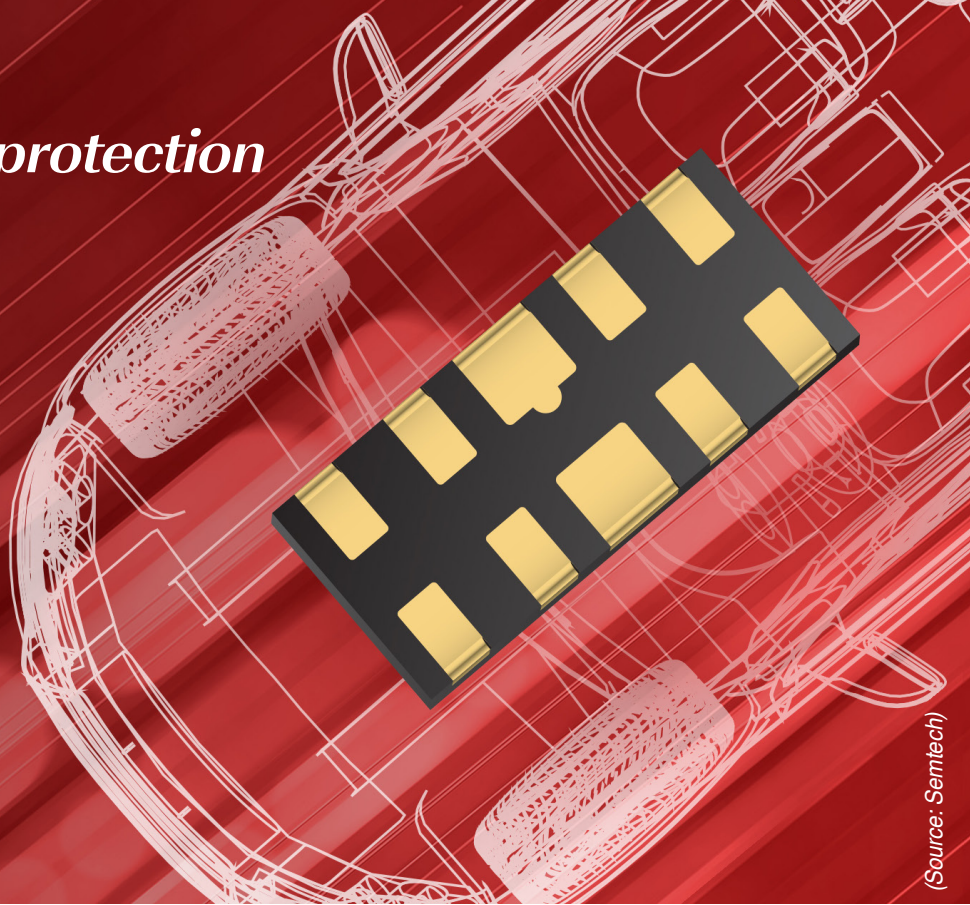

(Source: Semtech)

Motor vehicles have gone through much progress since their inception. Modern cars include autonomous and semi-autonomous driving, anti-lock braking systems, electric power steering, forward and rear collision warning, lane assistant, autonomous parking assistant, and automatic emergency braking. Advanced features such as GPS navigation, interior mood lighting, surround-view camera, advanced infotainment system, active antenna are standard in most modern vehicles.

Each vehicle feature is usually monitored and controlled by an individual electronic control unit (ECU). In a modern vehicle, there are about 50 ECUs to 100 ECUs, with each ECU responsible for one or more functions. The ECU works with multiple sensors such as the engine temperature sensor, air pressure sensor, door sensor, etc. It receives information from the sensors and adjusts the vehicle parameters under control accordingly. Sometimes one ECU may need to communicate with other ECUs to perform a designated function. For example, if you forget your car key in the ignition, the corresponding engine control ECU communicates with the door ECU to keep the door open and the speaker ECU to sound the alarm.

ECU communication via CAN

There are several in-vehicle network (IVN) protocols for data transmission between ECUs inside a vehicle. The most popular communication mechanism in modern vehicles is CAN. The bi-directional serial communication network allows ECUs to communicate without using any complex wiring. A twisted pair cable with a characteristic impedance of 120 Ω is used to transmit the data. One of the wires is called the CAN_Low (CAN_L) and the

other, CAN_High (CAN_H), with a data transfer rate of 1 Mbit/s. The ECU is connected to the CAN network via a CAN controller, similar to a micro-controller that handles all the necessary data processing activities. There is a CAN transceiver that interfaces between the CAN controller and the CAN network. It converts the transistor-transistor logic (TTL) signal into the actual differential voltage signal for the CAN network to read and interpret. The CAN architecture is shown in Figure 1.

Transient protection of CAN

When designing a CAN interface system in a harsh automotive environment with 50 ECUs to 100 ECUs, ensuring sufficient protection from electrical overstress events (EOS) is imperative. One of the primary causes of EOS is electrostatic discharge (ESD). Moreover, with the miniaturization of the electronic components, it is even more essential to protect the components from ESD threats and meet modern-day vehicles' safety and reliability requirements.

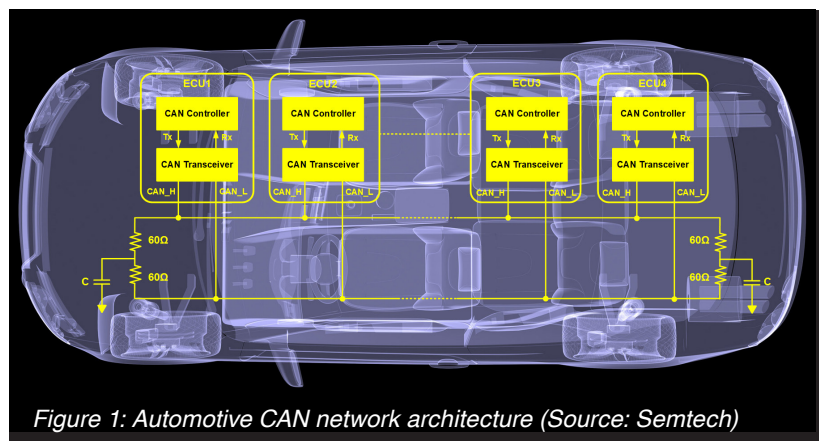

Figure 1: Automotive CAN network architecture (Source: Semtech)

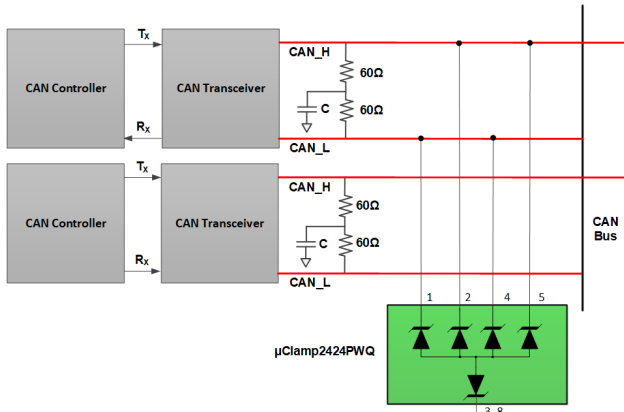

Figure 2: Possible ESD protection options of a CAN system (Source: Semtech)

Transient protection can be achieved by placing a transient voltage suppression diode on a CAN network data line to protect against transient events during the fast rise time in less than a nanosecond. Under normal operating conditions, the TVS diode presents a high impedance path to the protected circuit, so the device appears as an open circuit. It does not interfere with the rest of the circuit. During a transient event, the voltage on the terminals of the protected CAN transceiver can exceed safe operational limits. The TVS diode offers protection by providing a low impedance path so that the transient current is diverted away from the transceiver circuit. At the supposition of the ESD event, the TVS diode reverts to a high impedance state.

As mentioned before, the CAN network consists of two wires named CAN_H and CAN_L. CAN_H reaches 3,75 V when transmitting any data. At the same time, the CAN_L drops down to 1,25 V. When the CAN network is not transmitting any data, both CAN_H and CAN_L remain at 2,5 V. But we have to remember that a car generally uses a 12-V battery. Also, if a jump-start is required, it is done through a 24-V battery. So, the first criteria to select a TVS diode is the reverse working maximum voltage or VRWM, which should be sufficient to protect the CAN transceivers if the car's 12-V battery requires a jump-start from a 24-V battery in an emergency.

Another parameter that needs to be considered for selecting a TVS diode is the minimum breakdown voltage or VBR. It is the voltage when a TVS diode starts to conduct the current mentioned as a leakage current in the

product's datasheet in any transient scenario. Semtech's μ Clamp2424PWQ (shown in Figure 2) is a four-channel device that can protect two sets of CAN_H and CAN_L in the CAN network architecture. μ Clamp2424PWQ has an operating voltage of 24 V with a minimum breakdown voltage of 26,5 V. These voltages are sufficient to protect the CAN transceivers even if the vehicle needs to be jump-started.

Now let us talk about another vital parameter called clamping voltage or Vclamp. The Vclamp is the voltage of a TVS diode that appears across the device at the maximum peak pulse current rating. Vclamp determines the voltage that the device endures during a transient event. A lower clamping voltage is suitable for the protection of a CAN system or any other system. The typical clamping voltage of μ Clamp2424PWQ is 44 V at a maximum peak current of 5 A. Each device line is rated for a maximum EOS current of 5 A ($t_p = 8/20 \mu s$).

The CAN_H and CAN_L lines carry a differential signal with a maximum data-rate of 1 Mbit/s. Since they are high-speed differential data lines, TVS diodes should protect the circuit during transient events while ensuring signal integrity by maintaining a very low line-to-line capacitance. μ Clamp2424PWQ offers an extremely low capacitance of 15 pF (typ) and 18 pF (max) between the line and the ground. This fact makes it a suitable candidate to protect the CAN transceivers without undermining the signal integrity.

Conformance to level 4 IEC61000-4-2 standard and AEC-Q qualification are also mandatory requirements for automotive system design. μ Clamp2424PWQ provides transient protection to ESD events at ± 30 kV (Air) and ± 30 kV (Contact) as per the IEC 61000-4-2 standard. The device is available in a DFN (2,5 mm x 1,0 mm x 0,55 mm) package with state-of-the-art side wettable flanks for automatic visual inspection (AVI) post assembly. Figure 3 shows the features of μ Clamp2424PWQ.

Conclusion

Semtech is a leading manufacturer of TVS diodes that protects many of the world's high-speed automotive communication networks. In the harsh automotive environment, careful design and proper TVS diodes are crucial for safeguarding the communication networks and interfaces. Semtech's well-performing and reliable portfolio of TVS products protects high-speed automotive CAN as well as other communication networks. ◀

24V ESD and EOS Protection for 4-Line Automotive CAN Bus Applications

- Qualified to AEC-Q100(Grade 1) and AEC-Q101 (Grade 1)
- 24V, 4-line protection
- ± 30 kV/ ± 30 kV (air/ contact)
- 5A I_{pp} (8x20 μ s)
- 18pF max capacitance
- DFN 2.5 x 1.0 x 0.55mm
- Side wettable flanks

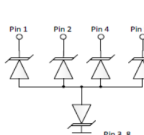
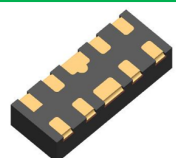
μClamp2424PWQ

Figure 3: Features of μ Clamp2424PWQ (Source: Semtech)

Author

Anindita Bhattacharya, PhD
Semtech
info@semtech.com
www.semtech.com



This article originally appeared on Inside Out, Semtech's corporate blog.