

CAN on construction sites



In cranes, pavers, earth-moving machinery, and other equipment used on construction sites, embedded CAN networks are used for many purposes. CANopen and J1939 are the most applied higher-layer protocols. The next step is the migration to CANopen FD and J1939-22.

(Source: Adobe Stock)

In 1994, CAN in Automation (CiA) established already the Special Interest Group (SIG) for mobile applications. It was chaired by Alfons Horn working with Moba. The CiA working group started to develop a CAN Application Layer (CiA 200 series) communication profile for construction machines. When the CANopen application layer and communication profile was handed over to CiA, the group decided to follow this path. Nowadays, Moba provides CANopen products for levelling and quality control of pavers, compactors, and milling machines.

At the same time mid of the 90s, U. S. manufacturers of earth-moving machinery adapted J1939 to control diesel engines. It took some time, to introduce worldwide CAN-based networks into construction machines and equipment, because this industry is conservative in adapting new technologies. Good things come to those, who wait. End of the 1990s, Prof. Dr. Wolfgang Poppy from the Otto-von-Guericke-Universität Magdeburg (Germany) was the

pioneer developing an excavator prototype controlled by CANopen networks. Some years later, many German suppliers of construction machines utilized CANopen in their products. In the meantime, many other European companies implemented CANopen in their machinery. They are supported by host controller manufacturers (e.g. Epec, Intercontrol, ifm, Moba, and STW) as well as sensor and actuator suppliers. The benefits are the standardized interfaces for encoders (CiA 406), inclinometers (CiA 410), modular I/O devices (CiA 401), etc. Products compliant with these CiA profiles are interoperable with the CANopen host controllers. However, exchangeability of such devices is limited to the mandatory functions.

Paving the future

Modern paving machines need multiple sensors. This includes especially sensors to control the levelling of road construction machines. Moba is one of the early birds providing such sensors with CANopen connectivity. Apparently, Chinese companies copied them. Some of these copies looked from the housing like the originals, but the function and quality were different. Paving roads and highways as well as runways require a sophisticated temperature control of the asphalt. This was also achieved with CANopen-connectable sensors.

Furthermore, CANopen networks are used in vehicle-mounted lifting equipment. Hirschmann (today: Wika) was one of the early users of CANopen Safety (EN 50325-5) for overload protection purposes in container, gantry, ▷



Figure 1: The Big Sonic-Ski from Moba with four CAN-connected sensors for asphalt paving (Source: Moba)

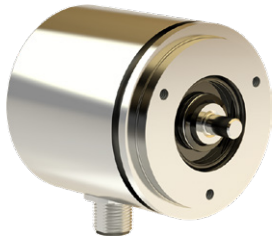

Figure 2: ABN sensor with a 22-bit resolution and CANopen or CANopen Safety connectivity (Source: TWK)

lattice boom, telescopic, and other cranes. For such kind of applications functional safe sensors are needed. CANopen Safety has been developed at the beginning of the millennium, originally released as CiA 304 specification.

Today, several CANopen host controllers (e.g. from ifm, Intercontrol, and STW) provide CANopen Safety support. There are also functional-safe pressure sensors, encoder, inclinometers, etc. available. For example, FSG and TWK have recently introduced new CANopen Safety encoders.

The miniature rotary encoder of the [MH609y-II-CAN series](#) from FSG feature CANopen and CANopen Safety. The starting point for the development was a previous customer solution for a small rotary encoder with a downstream signal converter for CAN, explained the company. FSG then developed the MH609y-II-CAN series, a cheaper and more compact solution without additional separate converters, the company continued. Signal output was via two CAN interfaces using the CANopen protocol.

At Hannover Messe 2022, TWK exhibited its [rotary encoders](#). They provide CANopen or CANopen Safety connectivity. The latest ABN encoder model has a resolution that divides the circle of 360° into over 4 million steps, which means a 22-bit resolution. This is impressive with better than ±10 arcsec, which is less than ±0,003°. Precise measurements of positions and speeds up to 10000 1/min are thus possible. These values are achieved by scanning an optical code disc. Equipped with the CANopen or CANopen Safety interface, the encoder can be used for safety-related applications. The requirements for SIL 2 (safety integrity level) according to IEC 61508 are fulfilled.

Moba has developed the MSS Slope CANopen Sensor family, which has been [EN ISO 13849 certified](#) by TÜV Nord. These sensors support CiA 301.

The next step: Migration to CAN FD

Some construction and earth-moving vehicles – nicknamed as “machines on wheels or caterpillars” – use multiple CAN-based networks. Some of them still use proprietary higher-layer protocols. But most utilize CANopen or J1939. In powertrain, J1939 dominates. CANopen is often used in the machine parts. If the CAN-based networks do not provide sufficient bandwidth, just another network segment is introduced. This is why many host controllers provide multiple CAN ports. In some applications, the separation of functions is not because of the busload, but because of functional separation provided by different development teams or sub-system suppliers.

If the busload is an issue, CAN FD could help. This second generation’s CAN protocol is now available in most of the micro-controllers. CAN HS (high-speed) transceivers and transceivers featuring signal improvement capability (so-called SIC transceiver) are provided by several chip-makers. But there is a hurdle to migrate to CAN FD: There ▶



Completely integrated automation for mobile machinery – X90

Complete portfolio:
www.br-automation.com/mobile-automation



- Easy handling
- Integrated safety
- Faster development



PERFECTION IN AUTOMATION
 A MEMBER OF THE ABB GROUP



is no specification for the network system design. CiA is going to fill the gap. The nonprofit association is looking for an academic partner to develop design recommendations for larger CAN FD networks. The research results should be usable for CANopen FD as well as J1939-22 (CAN FD based transport and application layer). J1939-22 adopted the multi-PDU (protocol data unit) concept, originally introduced in the CiA 602-2 specification (withdrawn after publication of J1939-22).

CiA profiles for construction machinery

In 2003, CiA released the CANopen application profile for sensor systems in road-construction and earth-moving machines (CiA 415 version 1.0.0). The predecessor of this specification was jointly developed by the Osyris (open system for road information support) consortium (terminated) and the European Asphalt Pavement Association (EAPA, www.eapa.org). The CiA 415 version 2.2.0 was released in April 2009. This application profile specifies the communication interfaces for sensors and a sensor controller of such road construction and earth moving machines as pavers, compactors, graders, dozers, mills, heaters, and trucks.

Profile-compliant sensors require a sensor controller (application commander and CANopen manager) supporting self-configuration of the CANopen network. During the start-up, the sensor controller scans the entire network for available sensors. Then, the number of process data entries provided by each sensor is read and verified using a plausibility test. If the number is valid, each process data entry is read out. Then, the sensor controller creates the necessary TPDOs for each device and downloads them to the sensors via SDO. First the PDO mapping parameters are configured followed by the PDO communication parameters. The same procedure is repeated for the required process data whereby the RPDOs for each sensor are created. After this process, the sensor controller switches the involved devices to the NMT operational state and tests whether the established PDO connections are working correctly.

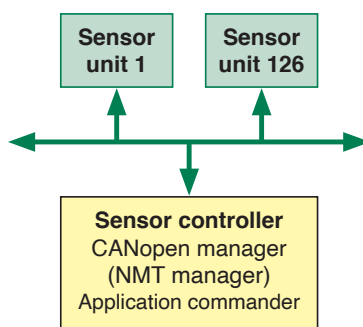

Figure 3: CiA 415 sensor system architecture example. Profile-compliant sensors require a sensor controller (application commander and CANopen manager) supporting self-configuration of the CANopen network. (Source: CiA)

Important system information is transferred with high priority using defined events for request/response of available sensor data, generic error transmission, machine state (stop, working etc.), leveling status (manual, auto, etc.), closed-loop control (automatic on/off), and begin of a new project (reset mode). Thus, the sensor controller device (usually residing in the on-board computer) is always informed on this information.

The general device parameters contain the

CAN Newsletter Online

The CAN Newsletter already reported several times about applications and products regarding CAN on construction sites. Here a few examples:

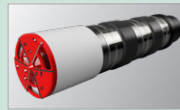

Tunnel drilling **"Not-a-boring" competition**

Elon Musk's Boring company has scheduled a competition to drill a tunnel faster than a snail.

[Read on](#)



Electrified **All-in-one solution for commercial vehicle PTOs**

The Eworx product family from ZF enables commercial vehicle power take-offs (PTOs) that are locally emission-free. Via CAN, the solution can be integrated into the vehicle's battery and energy management system.

[Read on](#)



CAN Newsletter magazine **Faster drilling for faster Internet**

Absolute CANopen encoders from Wachendorff provide position data in AT-Borettec's horizontal drill machines with automatic pipe feeding.

[Read on](#)



Moving detection **Mining safety kit for working in dangerous environments**

To reduce the risk of accidents and equipment damage in quarries, mines, and construction sites, VIA showcased the VIA Mobile360 AI Mining Safety Kit at the Conexpo-CON/AGG.

[Read on](#)



Fanless box PC **For construction machines**

The Rugged Computer Compact 8 by Syslogics complies with protection class IP67. It can be used in vehicles such as graders, wheel loaders, mining trucks, or dozers under extreme conditions.

[Read on](#)



Bauma 2016 **Driver's cab monitors surroundings**

Bosch was part of the Bauma 2016 and presents the Genius Cab. Using cameras and environmental sensors, drivers can monitor their surroundings and intuitively control vehicle functions via a display and joystick.

[Read on](#)



CAN network embedded **Radio-controlled crane**

F.lli Ferrari (Italy) has developed the 900 series of truck-mountable cranes. The cranes use embedded CAN networks.

[Read on](#)



Leveling system **Asphalt paving with a digital controller**

Leveling technology in asphalt pavers is a must for many projects. The Moba-matic leveling system and digital encoder helped level and pave a stretch of road in the north of Germany.

[Read on](#)

External CAN interfaces

End of the 1990s, the nonprofit Industrial Truck Association (ITA) developed some CANopen recommendations, how to use CiA profiles in forklifts. In the meantime, many OEMs (original equipment manufacturers) have implemented embedded CANopen networks in their battery-powered forklifts. One of the CANopen device suppliers is Curtis Instruments. The company offers color LCD displays, foot pedals and joysticks, sensors, I/O devices, and motor speed controllers for traction, steering, and hydraulic pumps. All these products implement configurable CANopen interfaces. Other features include motor auto-characterization routines and the proprietary Vehicle Control Language (VCL) application software helping OEMs to achieve maximum vehicle performance with minimum effort. For example, Curtis' CANopen motor controller (AC F2-A) and CANopen gauge (3140) are used in [Chinese pallet trucks](#).

Vetter, another supplier, has introduced the CANopen-connectable Smartfork sub-system, which enables [forklifts to become AGVs](#) (automated guided vehicles).

Jungheinrich uses [CANopen networks in its forklifts](#) since many years. In 2022, the ERE 225i pallet truck won the Red Dot design award. It uses an embedded CANopen network as the bigger trucklifts from Jungheinrich.



(Source: Jungheinrich)

The CAN Newsletter already reported several times about CAN used in forklifts. Here a few more examples:



Electric forklift **Counterbalance truck with lithium-ion battery**

Clark has relaunched the GEX and GTX series. The three and four-wheel electric forklifts in 48-V technology with load capacities of 1,6 t to 2 t are now also available with a lithium-ion (Li-ion) battery. The included control system uses CAN.

[Read on](#)



Battery charger **Energy storage in electric forklifts**

In the V-Force Energy Storage System (ESS) by Crown the battery charger communicates with the battery management system via CAN.

[Read on](#)



CAN Newsletter magazine **Covid-19: More pallet stackers and forklifts are needed**

In times of locked down economies with a lot of exit restrictions, online shopping increases. This causes more business for logistics companies requiring increasingly pallet stackers, forklifts, and other transportation equipment.

[Read on](#)



CANopen and J1939 **RFID solution for forklift vehicles**

The RFID (radio-frequency identification) industrial reader Bluebox Micro IA from Idtronic, is suited for industrial applications within intralogistical processes with a forklift vehicle.

[Read on](#)

information about the used machine (type, manufacturer, serial number etc.), provided and required process data, reference point for the measured coordinates, date and time as well as the operating hours. Process data includes the absolute 3D-position, angle position, curvilinear coordinates and angles, geographical coordinates, diverse



Figure 4: CANopen networks are used in vehicle-mounted lifting equipment. Wika, for example, uses CANopen Safety for overload protection purposes in container, gantry, lattice boom, telescopic, and other cranes. (Source: Adobe Stock)

deviation values, steering angle, machine speed, travelled distance, tool's rotational speed and extent, thickness of the laid or the removed layer, material volume and mass, flow values, diverse temperatures, road evenness, environmental conditions (wind, humidity, atmospheric pressure, and rainfall level) as well as the water tank level. For each consumed and each provided process data, a reference value parameter for configuration of a set-point is specified. The physical layer definitions accord to the CiA 301 and CiA 436 profile for construction machines. The latter defines also the error behavior of the sensor systems.

CiA 436 CANopen application profile for construction machines specifies the use of CANopen networks on construction machineries by introducing the virtual control architecture. The latter integrates the interfaces to the (diesel) engine control system, the drivers' desk, the sensor control system, the transmission control system, the fleet management control system, and the implement (superstructure) control system. CiA 436-1 specifies the integration network with the interfaces to the mentioned sub-systems. For each sub-system a separate application profile is specified (CiA 415 for sensor control) or is in development within further sub-parts of the CiA 436. ▶

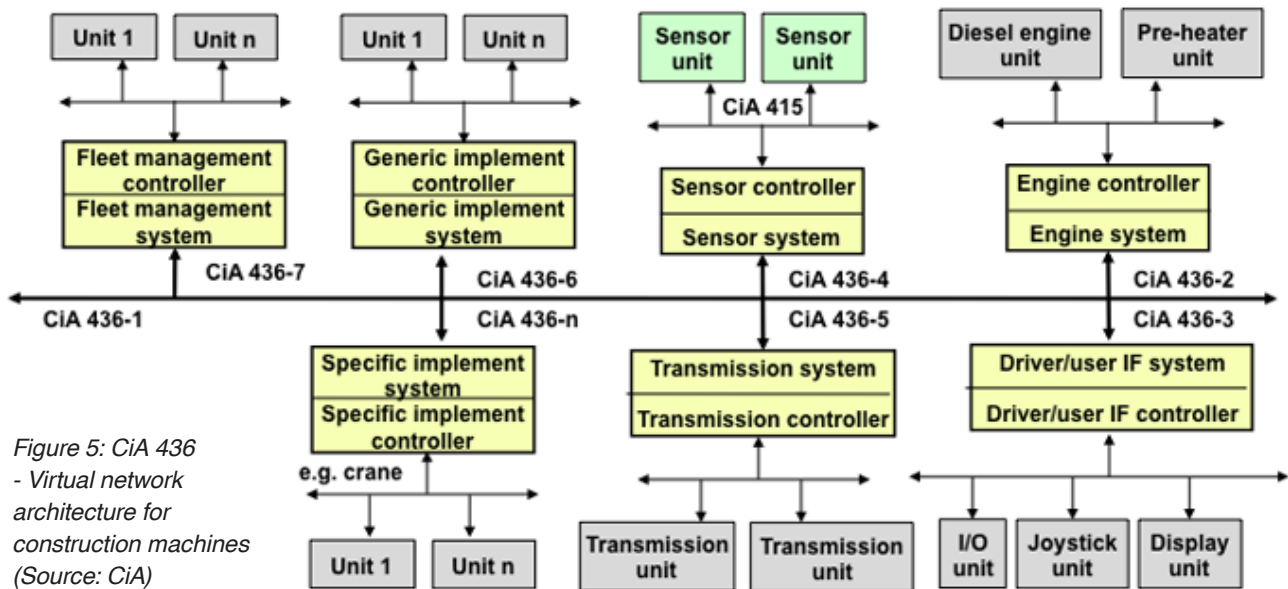

Figure 5: CiA 436 - Virtual network architecture for construction machines (Source: CiA)

The CiA 436-1 specification provides general definitions for construction machines. This series of documents has not been finalized yet. This is why CiA plans for 2023, to organize a workshop to discuss the demands for profiles related to any kind of construction and earth-moving

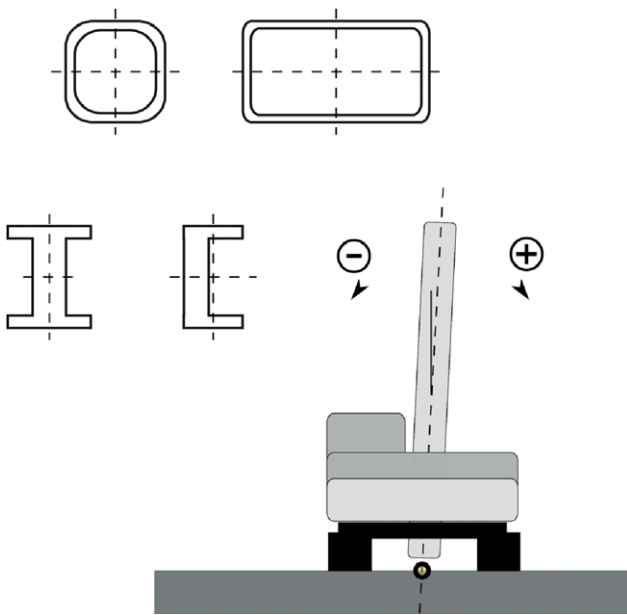

Figure 6: CiA 455 is suitable for all machines having a mast. Considering different mast profiles, the location of the reference point is illustrated in this Figure. (Source: CiA)

machines. The CiA 436-1 document recommends to use 5-pin micro-style (M12) connectors with a pin-assignment given in the CiA 106 technical report.

CiA has also developed a CANopen application profile for drilling machines. This CiA 455 specification covers the CANopen interfaces with regard on positioning

and tool control. It is suitable for all machines featuring a mast, which is mounted in the upper carriage. On this mast, the tool(s) are mounted. Depending on the machine, the mast can be moved along several axes in space as well as change its extension. The position of the mast is to be handled independently of the position of the machine's carriage. But the tool position depends on the mast position and alignment.

The center axis of the mast is defined as the axis of the centers of area of the whole mast. This is a well-defined axis (being identical with the geometrical center on a dual axial symmetrical profile). The location of the reference point is specified as intersection point between the axis of the mast and the ground level. Considering different mast profiles, the location of the reference point is illustrated in Figure 6. The coordinate system's x-axis is oriented to the magnetic north, the vertical z-axis pointing vertically upwards. The definition of the flask of reference for drilling machineries as well as for the location of the reference point is illustrated in the full CiA 455 specification, which can be [received from CiA](#) (for members it is free of charge).

CAN in Automation has a joint stand at the Bauma Munich construction and mining machinery exhibition from October 24 to October 30, 2022 and can be found in hall A2, stand 337. ◀



Author

Cindy Weissmueller
 CAN Newsletter
pr@can-cia.org
www.can-newsletter.org

